

# Resources / Links

General resources / links that are repeatedly referenced when developing firmware or are just generally helpful.

- [Raspberry Pi Pico 2](#)

# Raspberry Pi Pico 2

Most PCBs for IGVC and STORM use the Pico 2 as the microcontroller. It has low power draw and a lot of pins, and is also cheap enough that you can burn a few when starting out.

{idk insert other useful information here}

## Pinout

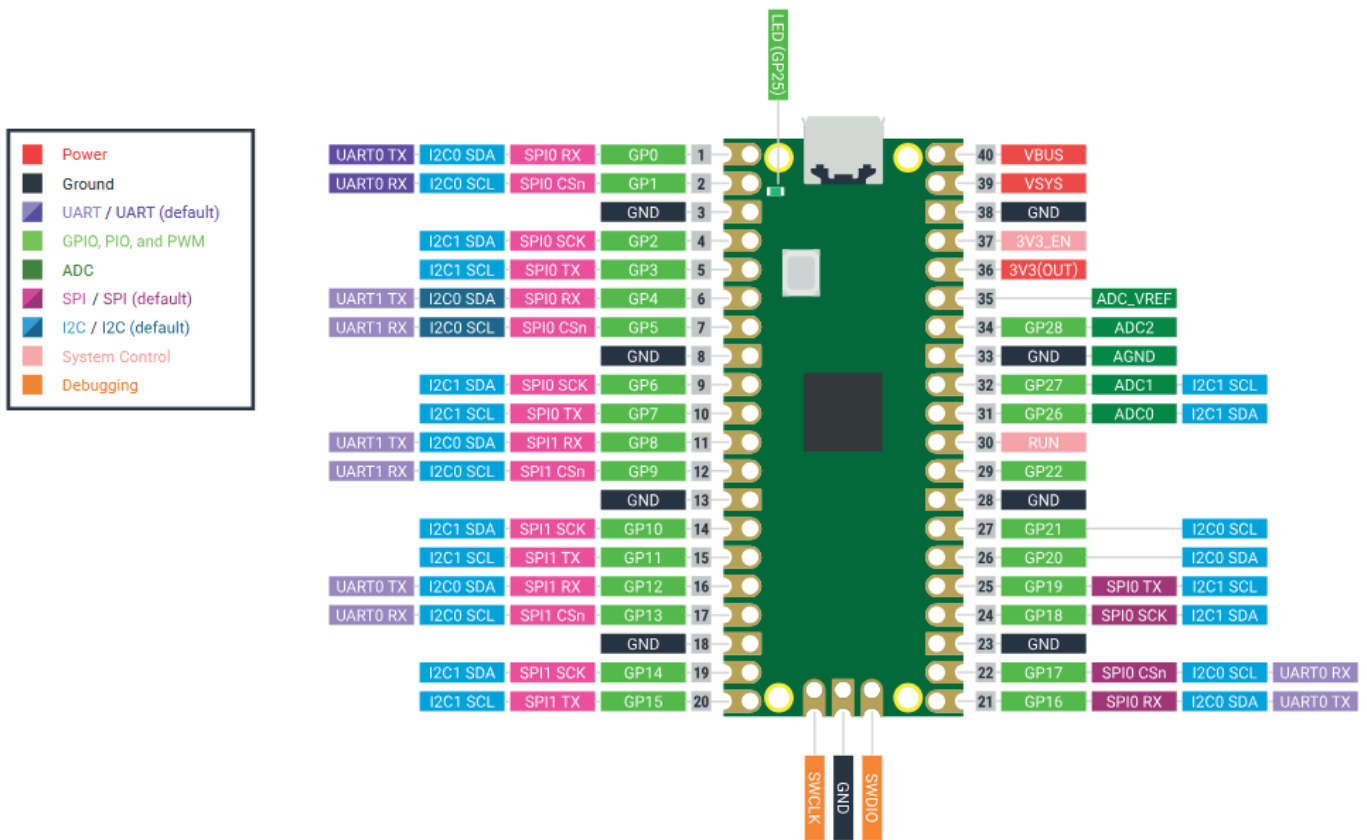

(from <https://datasheets.raspberrypi.com/pico/Pico-2-Pinout.pdf>)

## Datasheets

- [Pico 2 Datasheet](#)
- This datasheet is more useful for firmware writing/more in-depth: [RP2350 Datasheet](#)